



# PRECISION DIAMETER MEASUREMENT PRODUCTS

## InteliSENS™ BG Series Benchttop Diameter Gauges



HIGH PRECISION NON-CONTACT laser-based systems for instant measurement of individual samples, with preset tolerance monitoring, statistical analysis, and simple connection to PC or PLC



# PRECISION DIAMETER MEASUREMENT PRODUCTS

## InteliSENS™ BG Series Benchtop Diameter Gauges

### INTRODUCTION

The InteliSENS™ BG Series BenchTop high-precision laser micrometer measures discrete manufactured parts, or samples of continuously manufactured products, such as cable, wire, tubing, machined metal parts, and injection molded parts.

On the factory floor, operators and supervisors can quickly perform a highly accurate quality check of the dimensions of a manufactured product by simply placing it the sample holder. The diameter of the item is checked instantly to an accuracy of 0.008%.

The InteliSENS™ BG Series eliminates the possibilities of operator error inherent in the use of micrometers and other mechanical measuring equipment. Many different samples and products can be measured in rapid succession, as the BG Series of BenchTop gauges requires no adjustments between measurements.

The InteliSENS™ BG Series micrometers are extremely easy to use, and provide high-precision accuracy for each and every measurement.

Measurement data can be captured, stored and printed as part of your quality control system.

### NON-CONTACT MEASUREMENT

- Eliminates operator measurement error
- 100% quality inspection
- Compact, robust design for the factory floor
- Non-contact : no slippage & no marking
- Simple training - operator follows prompts
- Full SPC analysis with tables, charts and graphs
- RS232 comms in gauge head as standard

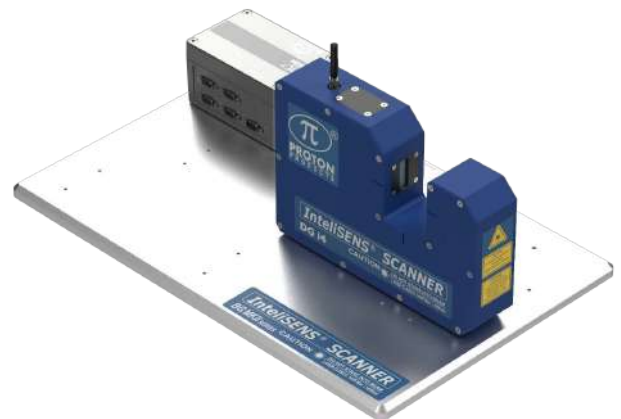

### KEY BENEFITS OF BG SERIES

- Reduce manpower - place inspection directly on the plant floor. Reduce part handling and extra manpower needed to inspect, transcribe, format and print reports. Remove steps, save resources.
- Absolute accuracy - readings taken directly from the gauge to eliminate operator error
- Faster inspection with automatic data logging - operator handles only the work loading and operating each inspection system. All of the data is automatically recorded. No wasted time writing down numbers. Production operators perform inspection and SPC reporting.
- Simple training - operator follows prompts. No need for the operator to learn complex software designed for engineers to use. Operators actually like to use the system.
- Find past data immediately full SPC analysis with control charts, histograms and tabulated results. All measurements and results are archived.
- Process control - SPC data is immediately available online. Supervisors can review the quality information on any shop order and take corrective action immediately.

# TECHNICAL SPECIFICATIONS

InteliSENS™	BG1030 MKII	BG1060 MKII
Min. diameter	0.1 mm (0.004inch)	0.2 m/min (0.008inch)
Max. diameter	27mm (1.063")	57mm (2.244")
Measurement rate	600 scans / second	600 scans / second
Accuracy	+/- 0.001mm (0.00004") +/- 0.008% of product size	+/- 0.0015mm (0.00006") +/- 0.008% of product size
Units of measurement	mm, inches	
Gauge power	24 Vdc 1 Amp	
Temperature range	5°C - 45°C (41°F - 113°F)	
Relative humidity	90% 38°C (105°F)	
SPC	SPC - Max, Min, Mean, Cp, CpK.	
HELIX	Measures the Enveloping Diameter of Stranded and Twisted Products	
Glass Logic	Measures Transparent Products	

## TRACEABLE CALIBRATION TO INTERNATIONAL STANDARDS

Proton InteliSENS™ BG Series Bench Top micrometers are permanently calibrated to United Kingdom Accreditation Service (UKAS) traceable standards. Due to the Multilateral Recognition Agreements in Europe, as endorsed by the European Union Co-operation for Accreditation, our UKAS traceable calibration method has European and US recognition.

## OPTIONAL MEASUREMENT FIXTURES

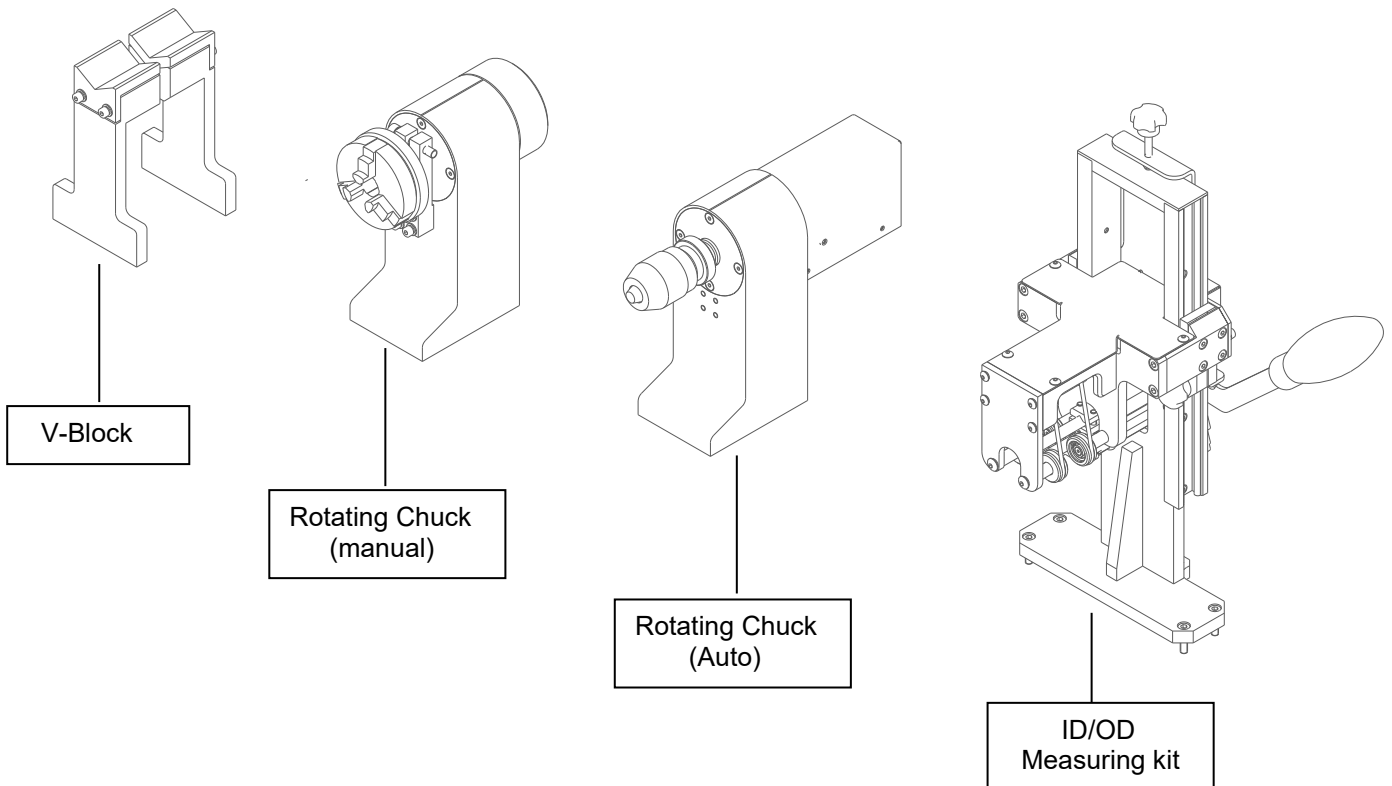

# PRODUCT DIMENSIONS

## IntelISENS™ BG1030 MKII

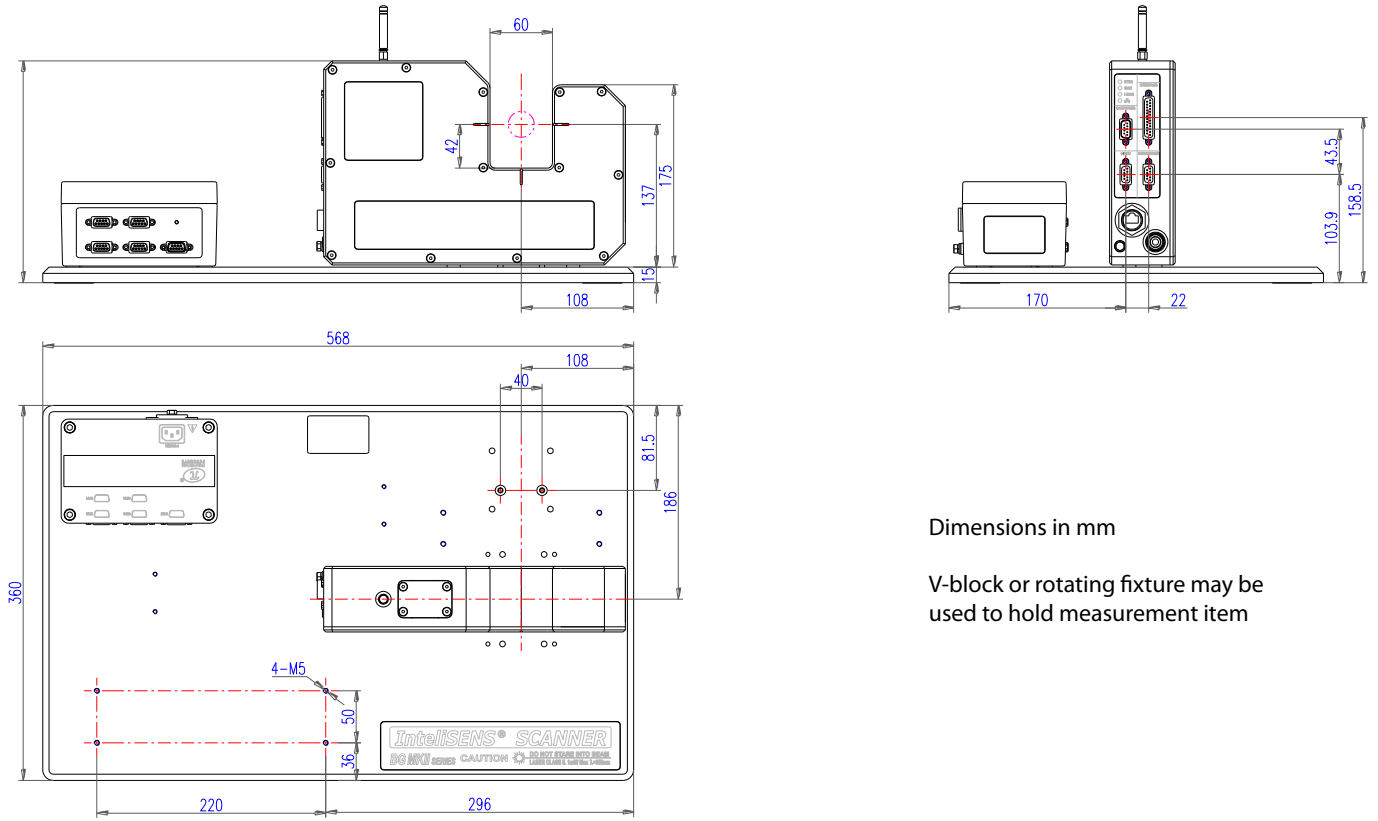

Dimensions in mm

V-block or rotating fixture may be used to hold measurement item

## IntelISENS™ BG1030 MKII with Option Items

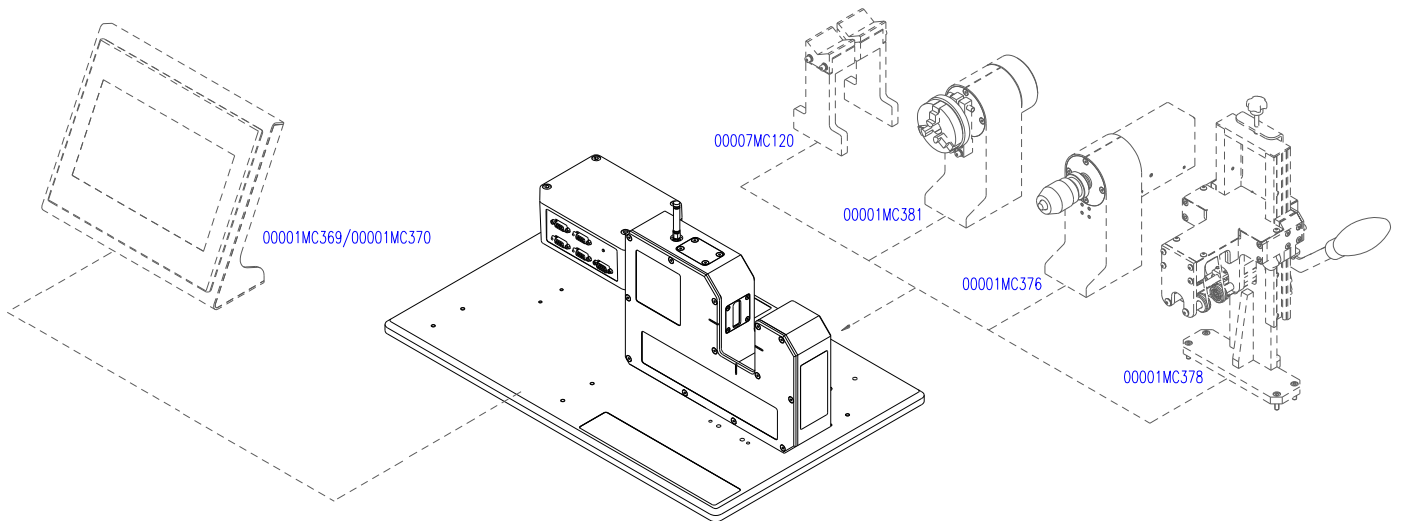

# CONTACT INFORMATION

## USA

**Proton Products Inc.**  
9272 Jeronimo Rd #110  
Irvine, CA 92618.  
United States  
Email : Sales@protonproducts.us

## EUROPE

**Proton Products Europe N.V.**  
TerspeltBusinessPark  
Koeweideblock 2/C13  
B-1785 Merchterm  
BELGIUM.  
Email : sales@protonproducts.eu

## ASIA

**Proton Products Chengdu Ltd.**  
No. 111, Checheng West 2nd Road,  
Longquanyi District, Chengdu,  
Sichuan Province 610100,  
CHINA.  
Email : sales@protonproducts.cn

## Thailand Agent

**Diamond International Co., Ltd.**  
555/46 Moo 4, Mahasawat,  
Bangkrui, Nonthaburi 11130,  
THAILAND.  
Mr. Kamnat Chyanimit  
Tel : +66 2038 7144  
Mobile : +66 8 9936 6895  
Email : sales@diamond-inter.com